

easyE[®] 35

Electric Linear Actuator

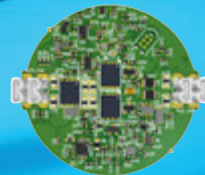

NEW
INTELLIGENT
Integrated
Controller



easyE-i
See datasheet at
www.easye.us

Bansbach
easylift[®]

Data Motor/Gear 12/24 VDC power supply, permanent magnet motor (Applicable to both standard and integrated controller options)

Gear Ratio	C*	D	E	F	G	H
Force 24V (dyn. push and pull) [N]	120	400	600	900	1600	2200
Speed at maximum load [mm/s]	33	16	12	7.5	4	3
Force 12V (dyn. push and pull) [N]	-	400	600	900	1500	2000
Speed at maximum load [mm/s]	-	16	9	7.5	3.5	2.5

Current at maximum load: **12VDC** (max 14VDC) = 3.6A, **24VDC** (max 28VDC) = 1.8A

Max. static load*/Self-locking force

*Depending on stroke length for push-applications

Temperature

Protection class

Cable specification

Materials

Duty cycle

Color

Stroke length/weight

- PA Brackets: 2000 N
- Alu Brackets: 5400 N
- Operation: -20°C to +70°C
- Storage: -40°C to +70°C
- IP66
- 1m, 2x0.25 mm² (AWG 22), diameter ~ 4 mm, black/grey
- Motor and actuator tube
- Front and rear brackets
- Piston rod
- Powder coated steel
- Max. 10% or 2 minutes in use followed by 18 minutes rest
- Stainless Steel
- Black (RAL 9005) is standard
- PA

Stroke	[mm]	50	100	150	200	250	300	350	400	500	750
Weight	[kg]	0.8	0.9	1.0	1.1	1.2	1.3	1.4	1.6	1.8	2.3

Type easyE 35 max. load limited to 1000 N for stroke lengths ≥ 500 mm. Actual weight may vary depending on model and options selected.

Options:

- Stainless steel versions (AISI 316)
- Front and rear brackets in aluminum or stainless steel
- Front and rear brackets with clevis
- Brackets with spherical bearings
- Hall sensors for positioning and/or synchronization
- Other cable lengths (1-9m)
- Connector types (Molex 5557/DIN 8 pole/Phono/Others)
- Low noise (not available in Stainless Steel)
- HE (Harsh Environment) version (gear ratio 1:4 not available). Tested according to IP68 and IP69 and passed the criteria for a depth of one meter for one hour. Test reports available upon request.
- Version certified according to IEC60601-1, ANSI/AAMI/ES60601-1, CAN/CSA-22.2 No60601-1 available (24 VDC only)
- ATEX zone 22, group II 3 D approval
- Tested according to EN/UL/CSA60.601

On request:

- Available in all RAL colors
- Other stroke lengths available
- Customized front, rear brackets and built in measures

Contact Bansbach for any special requirements

* The dust and water sealing of HE actuators might affect their performance in lower gear ratios

Speed/force

* 12V speeds:
G - 3.5mm/s
H - 2.5mm/s

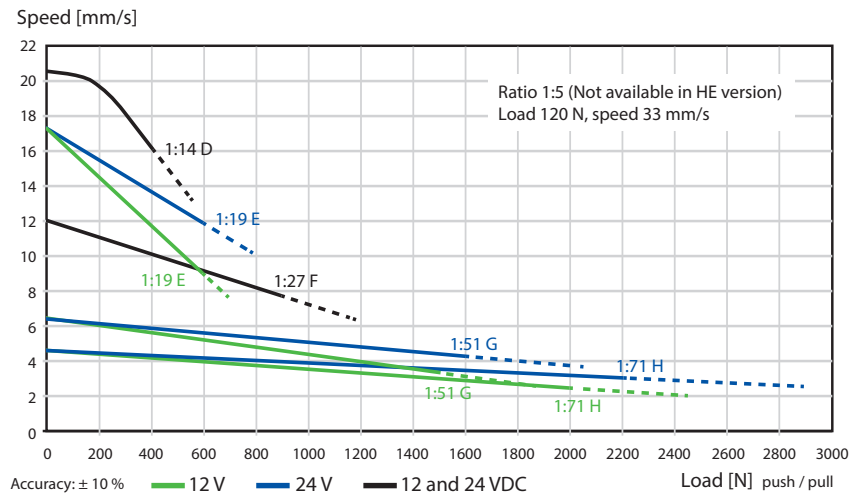

Force/current

Use in the dashed area is not recommended. Please contact Bansbach for further information.

1) At ambient temperature
T=25°C

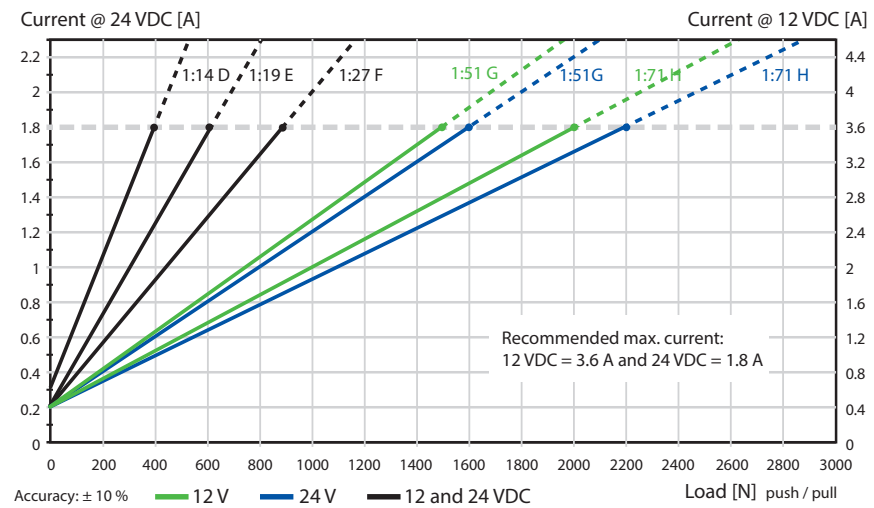

Dimensions

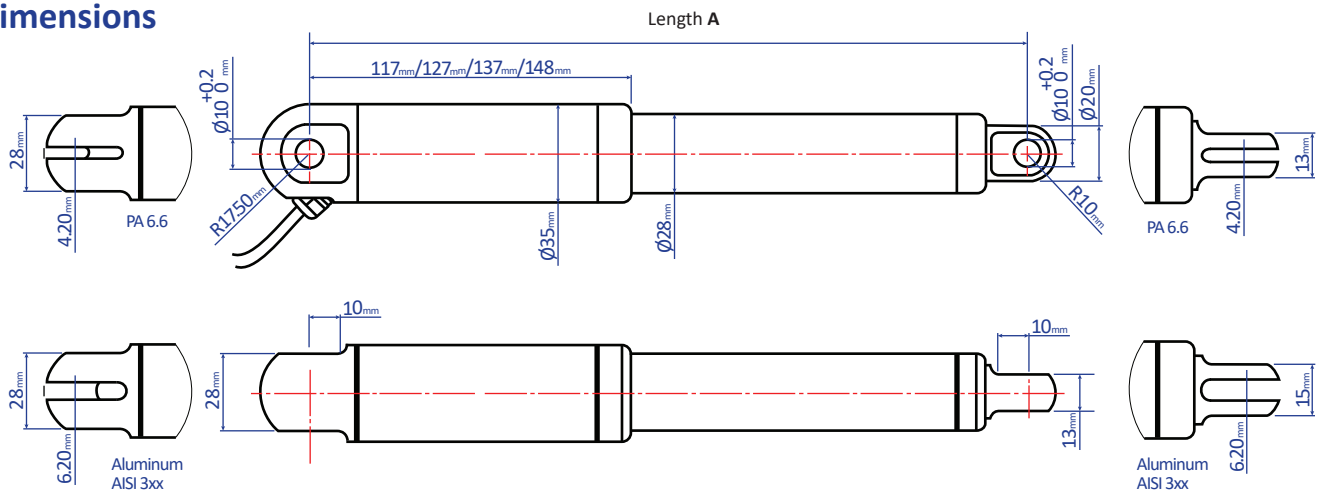

Axial backlash: ±0.5 mm
General dimensional variation: ±1 mm

Build length A [mm]	Standard	Clevis rear	Hall	UL/EN60.601	IP68 / 69K	easyE-i
Gear ratio C, D, E, F	160+s*	+10	+10	+10	+11	+10
Gear ratio G, H	170+s*	+10	+10	+10	+11	+10

*s = stroke length

stroke length ≤ 500 mm: + 7 mm
stroke length ≤ 700 mm: + 42 mm

Precautions

Power supply without over current-relay or other current switch-off devices can cause serious damage to the actuator at mechanical end-stop stop or if the actuator is overloaded in another way. Radial forces might have an adverse effect of the performance of, or lead to damage to the actuator.

Standard Brackets

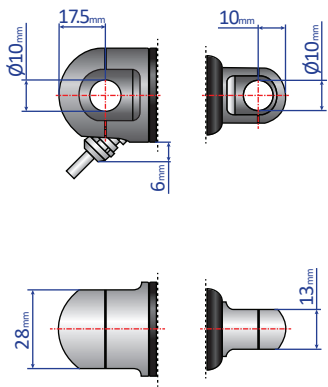

Alu / AISI316
Max. static load 16800N

Hinge Eye
A1 – Aluminum
B1 – Plastic (PA)
C1 – Stainless Steel

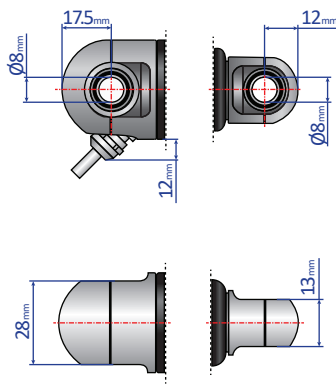

Alu / AISI316 with spherical bearings
Max. static load 11000N

Hinge Eye with Spherical Bearings
E1 – Aluminum
J1 – Stainless Steel

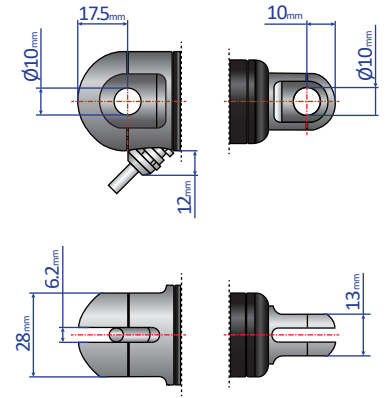

Alu / AISI316 with clevis
Max. static load 16800N

Clevis
F1 – Aluminum
G1- Plastic (PA)
H1 – Stainless Steel

Recommended Mounting Methods

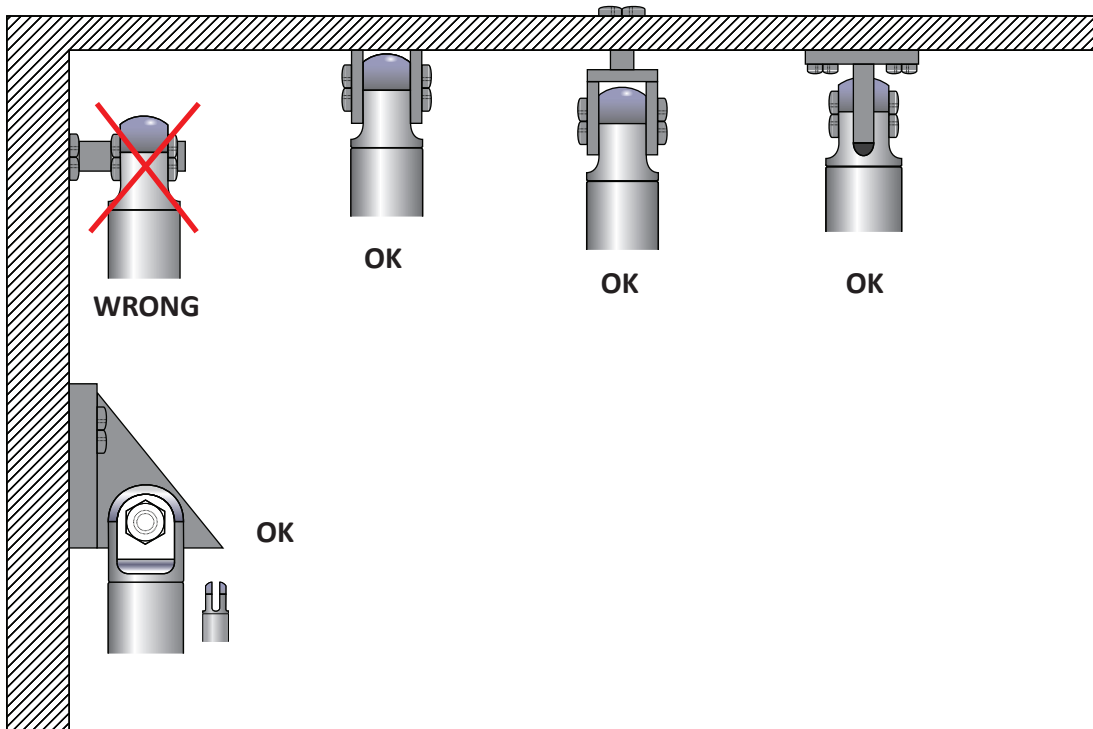

- Do not clamp actuators on tubing
- Always keep both brackets mounted in the same orientation and ensure to flush mount actuator
- Brackets must always be able to rotate on axels in mountings

easyE® 35 Item Number Combination

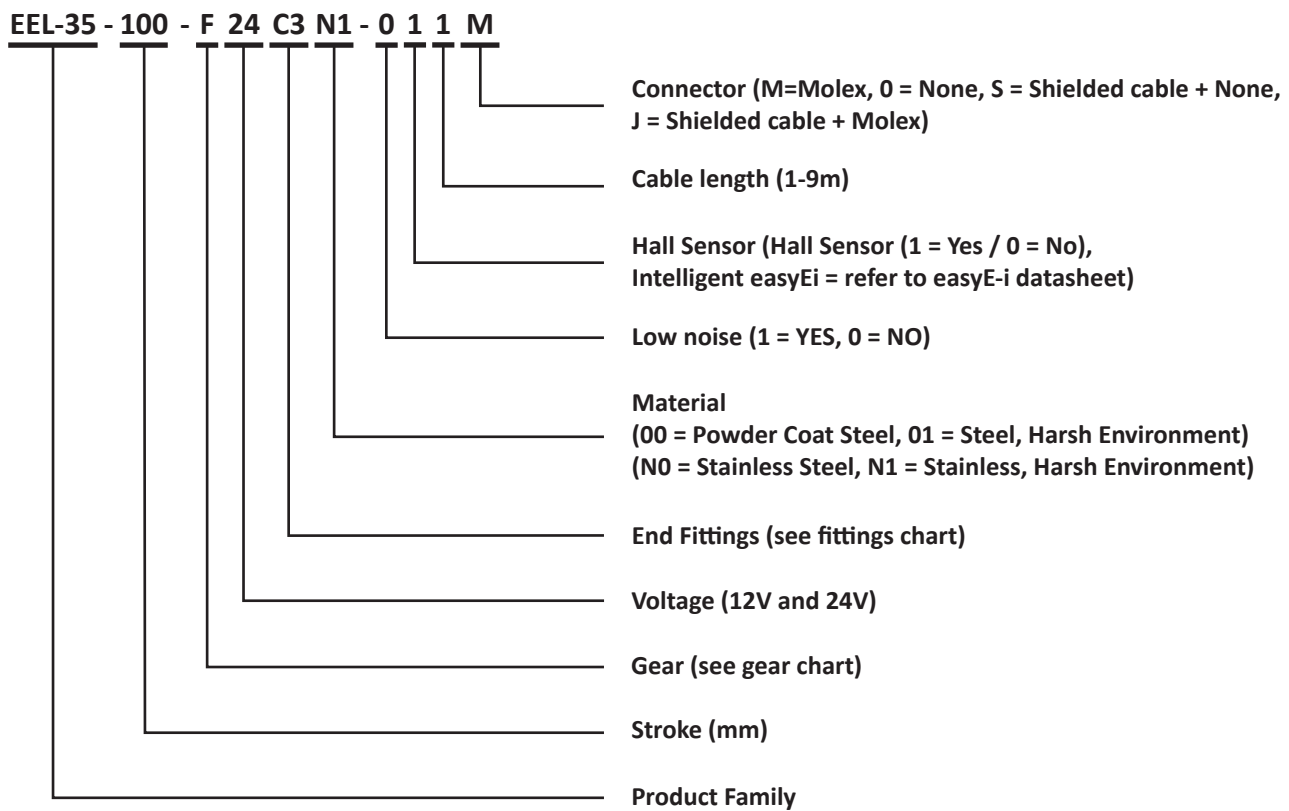

Please Note

- Power supply without over-current protection can cause serious damage to the actuator at mechanical end-stop or when actuator is overloaded in another way
- Radial forces might have an adverse affect on the performance or lead to damage of the actuator
- Keep piston tube clean
- Longer cable lengths may cause voltage drop which affects the performance of the actuator
- For medical applications maximum ambient temperature is 48°C
- Function of the actuator is subject to the settings of the control box
- Bansbach does not have any responsibility for possible errors in this data sheet
- Specifications are subject to change without notice
- The dust and water sealing of Harsh Environment actuators might affect their performance
- All specifications are for 25°C ambient – low temperature might affect their performance
- Depending on load and application, nominal and actual stroke length may differ due to internal disc springs not being fully compressed

Disclaimer

- Modern production processes and a certified quality system, guarantee that Bansbach products are of the highest quality standard. It is always the responsibility of the customer to examine the appropriateness of the application and environment for each product.
- Bansbach is not responsible for any errors found within this document. Information is subject to change without notice.

For more information, please visit our website at: www.bansbach.com

Bansbach Easylift of North America, Inc.

50 West Drive
Melbourne, FL 32904

Tel: (321) 253-1999
Fax: (321) 253-5546

sales@easylift.com
www.easylift.com

Bansbach
easylift®